

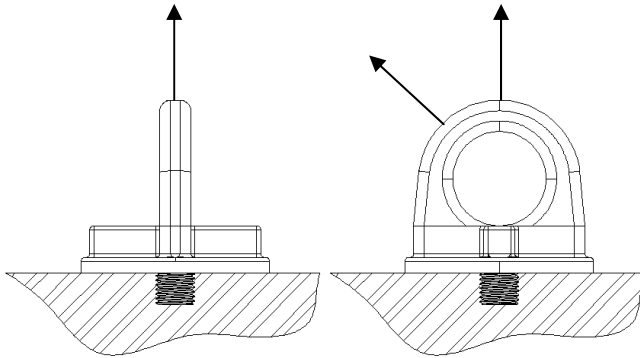

## Heavy Duty<sup>®</sup> Safety Lift Eye SAFETY INSTRUCTIONS

**CAUTION: PRIOR TO USING HEAVY DUTY<sup>®</sup> SAFETY LIFT EYE, PLEASE READ THE FOLLOWING FOR PROPER INSTALLATION AND USAGE.**

- As with all mechanical devices, regular inspection for wear and strict adherence to use instruction is necessary to prevent misuse failure.
- **Caution:** Do not apply side loads in direction shown in FIG 2 below. Listed capacities are maximum safe working load.
- Despite the 5:1 safety factor, **NEVER EXCEED THE RATED LOAD CAPACITY.**
- Always screw down completely for proper seating. Tighten mounting screws securely against the load. Periodically check because screws could loosen with extended service.
- Tensile strength of parent material should be above 50,000 PSI to achieve full load rating.
- **AVOID SHOCK LOADING.** Always lift gradually. Repeat magnetic particle inspection if shock loading ever occurs.
- When more than one lift eye is used in conjunction with multiple-leg rigging, spreader bars, lifting yokes or lifting beams should be used to reduce angular loading.
- **Angular loading should be avoided. Angular loading occurs in any lift in which the lifting force is applied at an angle to the centerline of the eyebolt shank.**



**FIG 1**  
**CORRECT**

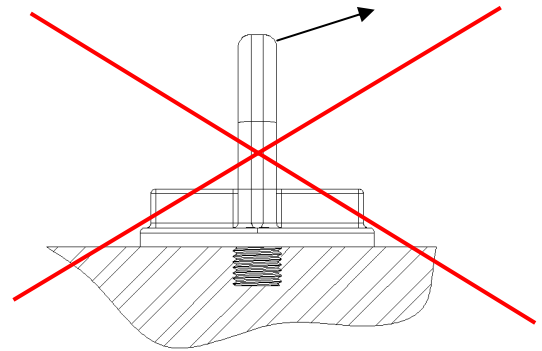

**FIG 2**  
**INCORRECT**

- Mounting surface must be flat and smooth for full contact with the universal lift rings base.
- Tapped mounting holes must be perpendicular to the mounting surface.
- Always inspect lift eye before use.
- Never use lift eye that shows signs of wear or damage.
- Never use lift eye if eye or threads are bent or elongated.
- Always be sure threads on shank and receiving holes are clean.
- Never machine, grind or cut lift eye.