



Flip-Flop Hoist Ring SAFETY INSTRUCTIONS

CAUTION: PRIOR TO USING ANY HOIST RING, PLEASE READ THE FOLLOWING FOR PROPER INSTALLATION AND USAGE.

As with all mechanical devices, regular inspection for wear and strict adherence to use instruction is necessary to prevent misuse failure.

- Despite the 5:1 safety factor, NEVER EXCEED THE RATED LOAD CAPACITY.

- Tighten mounting screws to recommended torque. Periodically check torque because screws could loosen with extended service.

Note: if weld mounting, weld must be performed by a certified welder

- Tensile strength of parent material should be above 80,000 PSI to achieve full load rating. For weaker material, consider through-hole mounting with a nut and washer on the other side.

- DO NOT APPLY SHOCK LOADS. Always lift in gradually. Repeat magnetic particle testing if shock loading ever occurs.

• After installation, always check that ring pivots freely 180°.

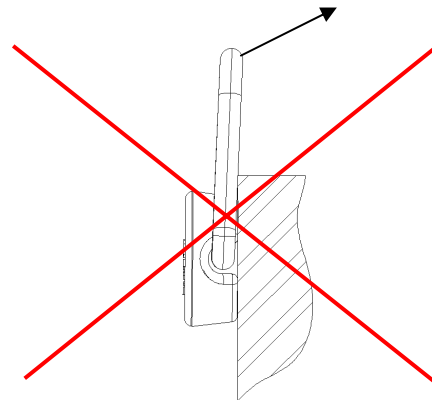
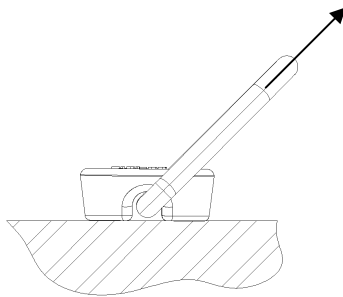
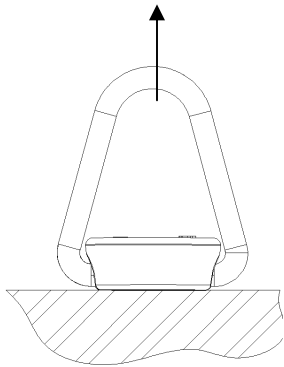

CORRECT

INCORRECT

IMPORTANT! The force on each hoist ring is not just the total weight divided by the number of hoist rings. The force will be greater at lower lift angles. Make sure load is evenly distributed. See below.

Formula with example data:

$$F = \frac{W}{N \sin A}$$

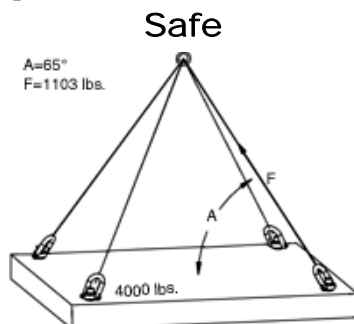

Fig. 1

A = 65°
F = 4000 / 4 sin65° = 1103 lbs.

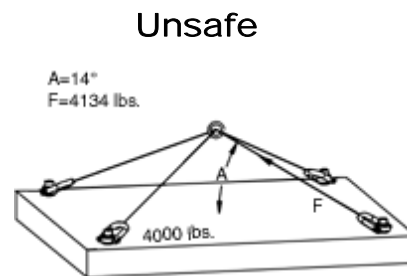

Fig. 2

A = 14°
F = 4000 / 4 sin14° = 4134 lbs.

F = Force on each hoist ring
W = Total weight = 4000 lbs.
N = Number of hoist rings = 4
A = Lifting angle